



Transplanters - Hole Punchers

HOLE PUNCHER

There are many production methods that do not call for transplanting at the exact moment that the hole is punched through the mulch. For those growers who simply need to punch holes through plastic mulch, we make two different styles of hole punchers.

Our PS439 hole puncher is a simple three-point mast that accepts a floating wheel frame. The side wheels keep the puncher centered over the planting bed and allow the punch wheels to ride over the top of the bed. This hole puncher can be used with 1, 2 or 3 punch wheels.

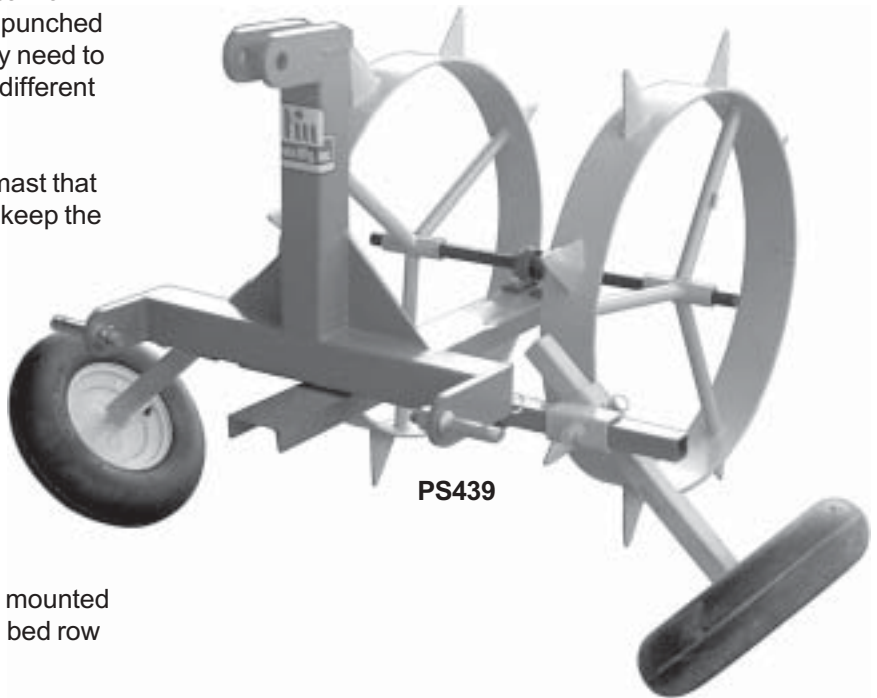

Our PS437 hole puncher is popular with growers planting on wider than normal beds, and punching more than three rows of holes. The punch wheels are mounted inside a suspended frame that allows them to float on top of the bed and side to side when necessary. Any number of punch wheels can be mounted inside the wheel frame depending on the planting bed row center spacing and punch sizes.

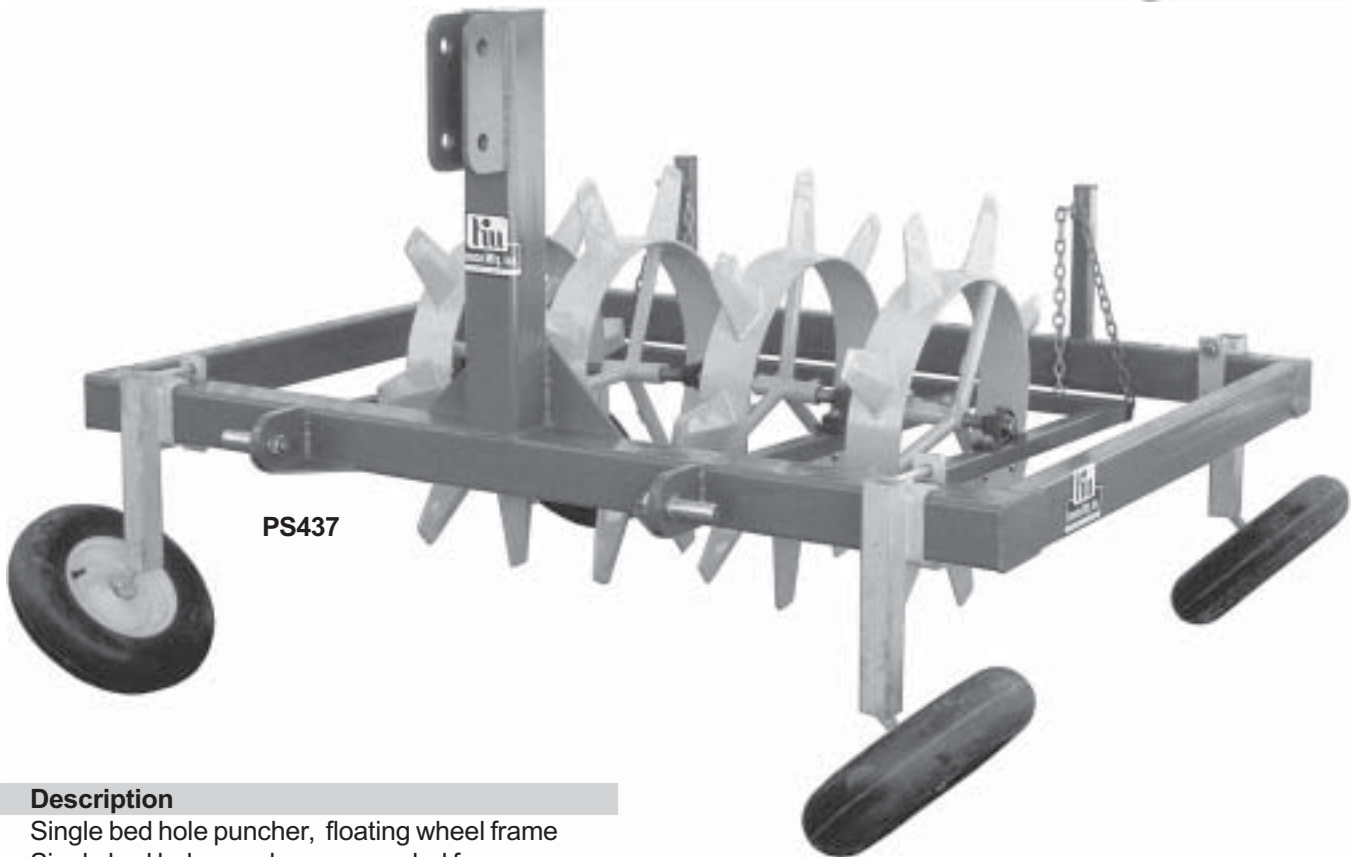

Part #	Description
PS439	Single bed hole puncher, floating wheel frame
PS437	Single bed hole puncher, suspended frame

Customers must specify bed width and row spacing when ordering. Hole punchers most commonly use dry punch wheels. Customer specifies number of wheels, punch spacing, punch depth & width, and punch style for planter wheels. Wheels are not included with hole punchers and must be ordered separately. Call our sales department for weights and dimensions.